

ZONE	REV	DESCRIPTION	DATE	APPROVAL
	1	PRELIMINARY RELEASE	1/4/2017	CN

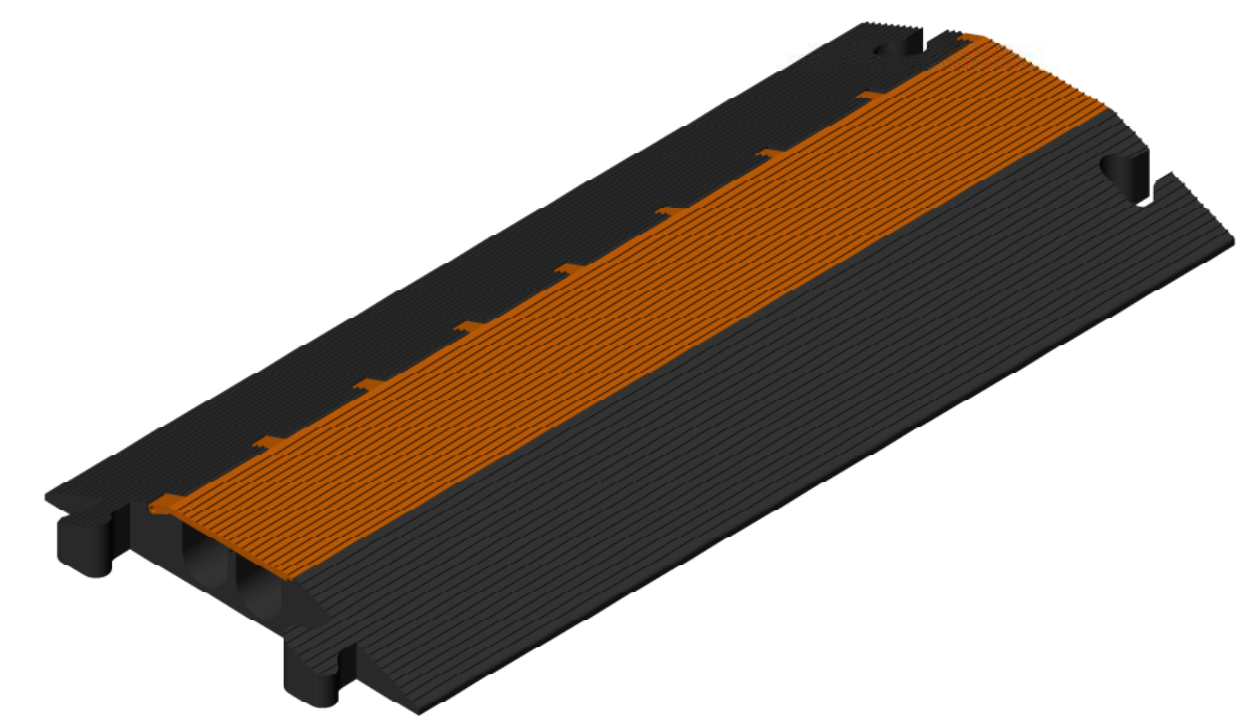
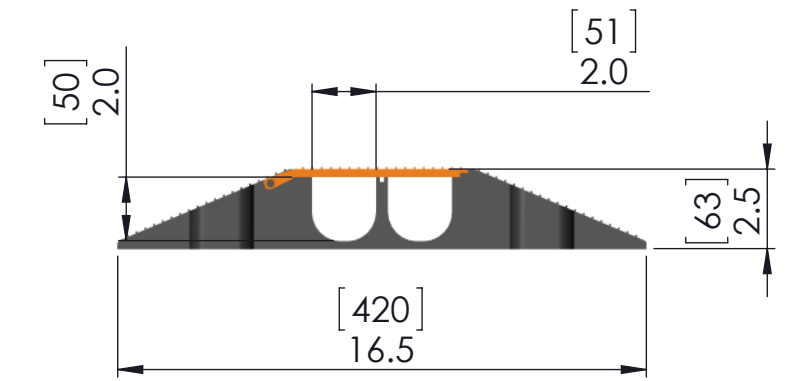
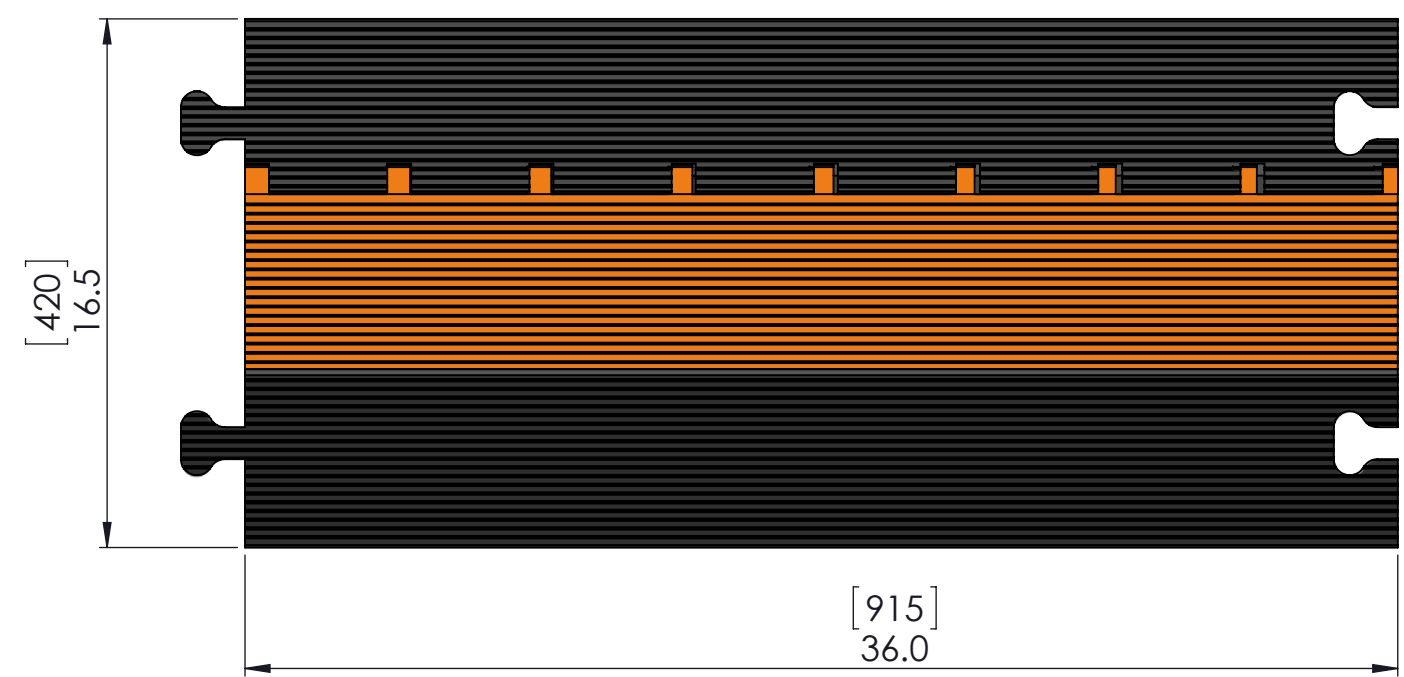

Technical Data Sheet - MG2200		
Description	Imperial	Metric
Product - Length x Width x Height	36 x 16.5 x 2.5	915 x 420 x 63
Channel Size	2 x 2	51 x 51
Product Weight (lbs)	25.5	11.5
Load Capacity (lbs/axle)	33,000	14,970
Operating Temperature	-20°F up to +140°F	-30°C up to +60°C
Measurements are approximate	Imperial = inches & lbs.	Metric = mm & kg.

Standard Colors - Black Base/Orange Lid
Material - Polyurethane
Durometer - 90 Shore A Base +/- 5 --- 55D Shore D Lid +/-5
Manufacture in USA

PROPRIETARY AND CONFIDENTIAL THE INFORMATION CONTAINED IN THIS DRAWING IS THE SOLE PROPERTY OF THE ESAC. ANY REPRODUCTION IN PART OR AS A WHOLE WITHOUT THE WRITTEN PERMISSION OF THE ELASCO IS PROHIBITED.	UNLESS OTHERWISE SPECIFIED: DIMENSIONS ARE IN INCHES TOLERANCES: FRACTIONAL: ± 1/32 ANGULAR: MACH ± 1° BEND ± 1° .X = ± .1 .XX = ± .01 .XXX = ± .005	Elasco Products, LLC 18065 Redondo Circle Huntington Beach, CA 92648	
	UNLESS OTHERWISE SPECIFIED DIMENSIONS AND TOLERANCES PER ASME Y14.5M	DRAWN: CN 1/4/2017 CHECKED: APPROVED: ELECTRONIC SIGNATURE ON FILE	TITLE: MIGHTY GUARD 2 Channel at 2.0" SIZE: B DWG. NO. MG2200 REV 1